

Product: KLUDI D-VISE single lever basin mixer DN 10

Ref.: 371810590

Product description

single lever basin mixer DN 10
 solid lever
 single hole mounted
 flow class Z
 eco-aerator M 24 x I
 ceramic cartridge with hot water safety device
 pop up waste 1 1/4 inch
 rapid installation set
 flexible high pressure supply tubes 3/8 inch
 noise level I

Finishes:
 05 chrome

Product picture

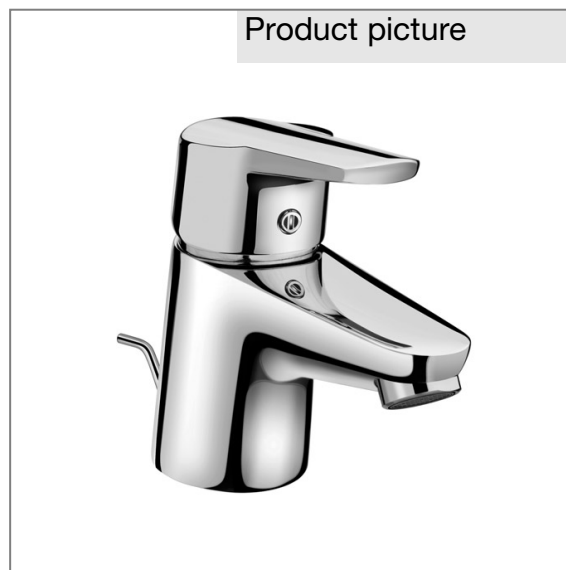

Advertisement

- * KLUDI GmbH & Co KG KLUDI D-VISE single lever basin mixer item no. 371810590
- ** ceramic cartridge with hot water safety device Ø 35 mm, DIN EN 817
- *** chrome plated brass, DIN 50930-6

single lever basin mixer, manufacturer KLUDI GmbH & Co KG KLUDI D-VISE single lever basin mixer item no. 371810590, DN 10, finish 05 = chrome plated brass, ceramic cartridge with hot water safety device Ø 35 mm, solid lever, noise level DIN EN 4109 group I = ≤ 20 dbA, type: single lever basin mixer DN 10, flow class Z (max. 0,15 l/s), Eco aerator M 24 X I Z, pop up waste 1 1/4 inch, flexible high pressure supply tubes 3/8 inch with DVGW / KIWA / WRAS / CSTB with metal body length 350 mm, nozzle projection 100 mm, nozzle height 58/78 mm, lever projection 78 mm, rapid installation set, overall length 124 mm, for pressure type water heater, for continuous line heater, PN 10,

Dimensional drawing

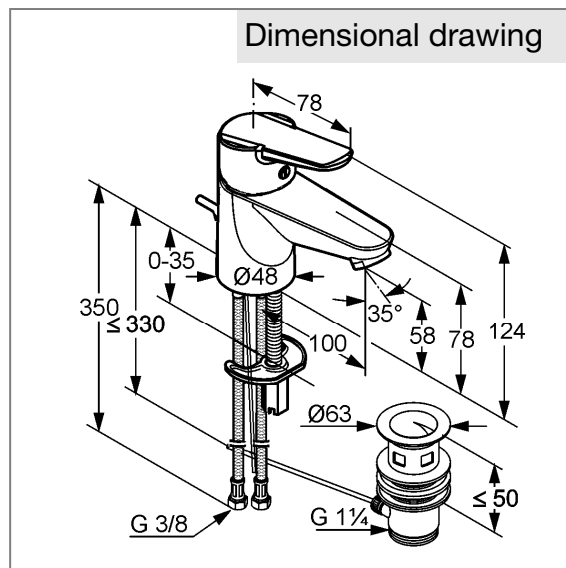

Flow rate diagram

