

CONFLUO PREMIUM LINE



CONFLUO PREMIUM LINE

Peštan Confluo Premium LINE drain made from polipropilen with ABS made grid holder, with no side inlets and one horizontal DN 50mm output, minimum installation height of 52mm and flow rate of 48 l/min. Base of drain without socket with water sealing height of 25 mm, with height adjustable reducer for linear drain and feet for height and inclination adjustment and with hair stopper. Stainless steel grid with the possibility of installing tiles, marble or tempered glas in it. Stainless steel mask and stainless steel grate class K3, dimensions 278x54 mm.

IMPORTANT TECHNICAL INFORMATION	
Minimal instalation hight	52mm
Lenghts(numbers represent lenght of the grid)	300mm , 450mm , 550mm , 650mm , 750mm , 850mm
Width of grid carrier/mask/grid	120mm/94mm/55mm
Flow (in accordance with EN1253)	48 l/min
Output	Ø50mm
The height of the water plug	25mm
Maximum height of ceramics within the grid and the grid	12mm/14mm
Load class of the grid (in accordance with EN 1253)	K3 - withstands 300 kg pressure
Grid material	Stainless steel AISI 304 (optimal AISI 316) with the possibility of installing selected ceramic in the grid
Drain body material	ABS (grid carrier)/PP (reducer,base)

MAIN ADVANTAGES:

- a) Low installation height - 52mm
- b) High flow rate - 48 l/min
- c) Modular and Flexible - 2 in 1 system
- d) Easy installation & maintenance
- e) 360° rotatable self-cleaning S base
- f) Elegant glass grid with chamfered edges

52 mm	48l/min	2 in 1 system	SC/L	K3
50 output	360° base rotation	25 mm	AISI 304	

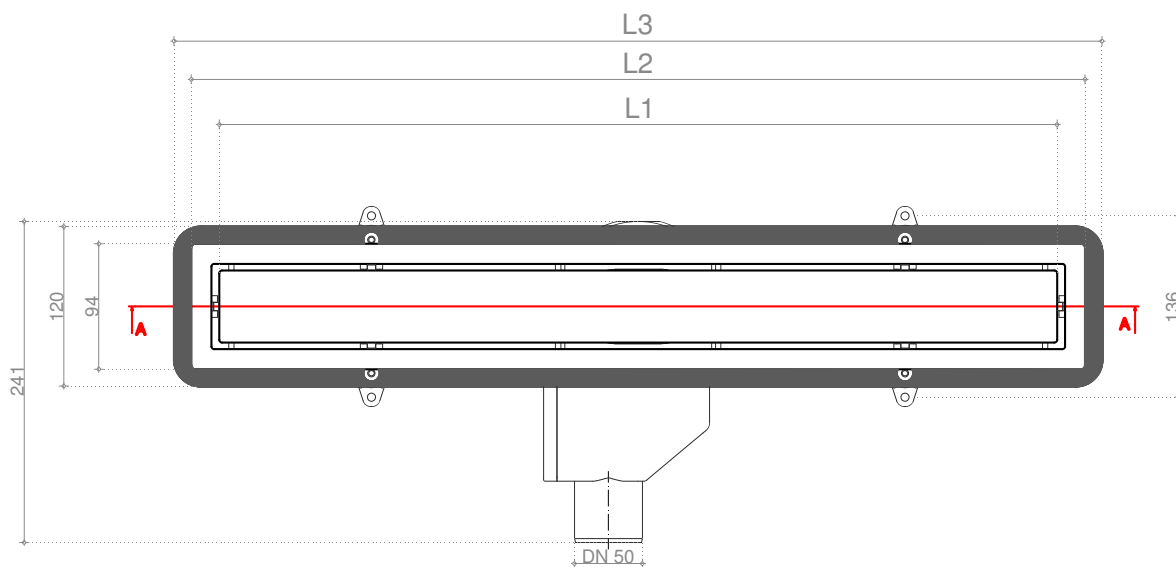
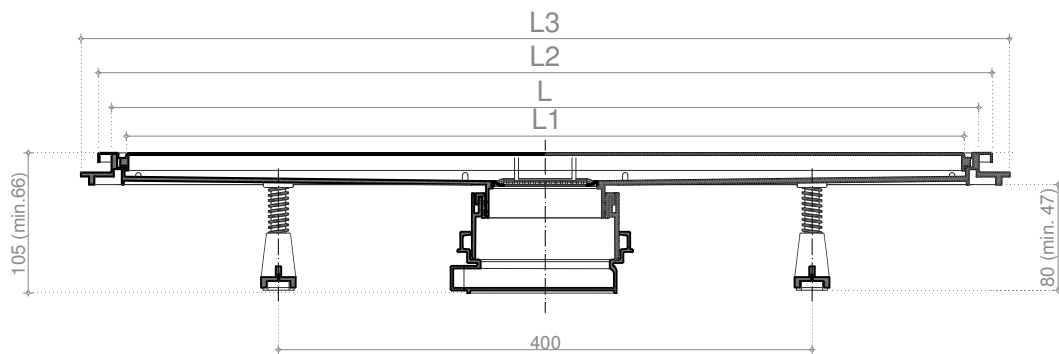

NOTE: Drains in length of 300, 450, 550 and 650 come in package with two sets of legs for adjusting of height. Drains in length 750 and 850 come in package with four sets of legs for adjusting of height.

L mm	300	450	550	650	750	850
L1 mm	278	428	528	628	728	828
L2 mm	320	470	570	670	770	870
L3 mm	346	496	596	696	796	896



Code	Name	Weight	Box dimensions
13100001	CONFLUO "PREMIUM LINE 300"	1,044 kg	674mm x 170mm x 130mm
13100002	CONFLUO "PREMIUM LINE 450"	1,3 kg	674mm x 170mm x 130mm
13100003	CONFLUO "PREMIUM LINE 550"	1,49 kg	674mm x 170mm x 130mm
13100004	CONFLUO "PREMIUM LINE 650"	1,655 kg	904mm x 170mm x 130mm
13100005	CONFLUO "PREMIUM LINE 750"	1,935 kg	904mm x 170mm x 130mm
13100006	CONFLUO "PREMIUM LINE 850"	2,115 kg	904mm x 170mm x 130mm

13000297	CONFLUO "PREMIUM LINE 300" +	1,044 kg	674mm x 170mm x 130mm
13000298	CONFLUO "PREMIUM LINE 450" +	1,3 kg	674mm x 170mm x 130mm
13000299	CONFLUO "PREMIUM LINE 550" +	1,49 kg	674mm x 170mm x 130mm
13000300	CONFLUO "PREMIUM LINE 650" +	1,655 kg	904mm x 170mm x 130mm
13000301	CONFLUO "PREMIUM LINE 750" +	1,935 kg	904mm x 170mm x 130mm
13000302	CONFLUO "PREMIUM LINE 850" +	2,115 kg	904mm x 170mm x 130mm

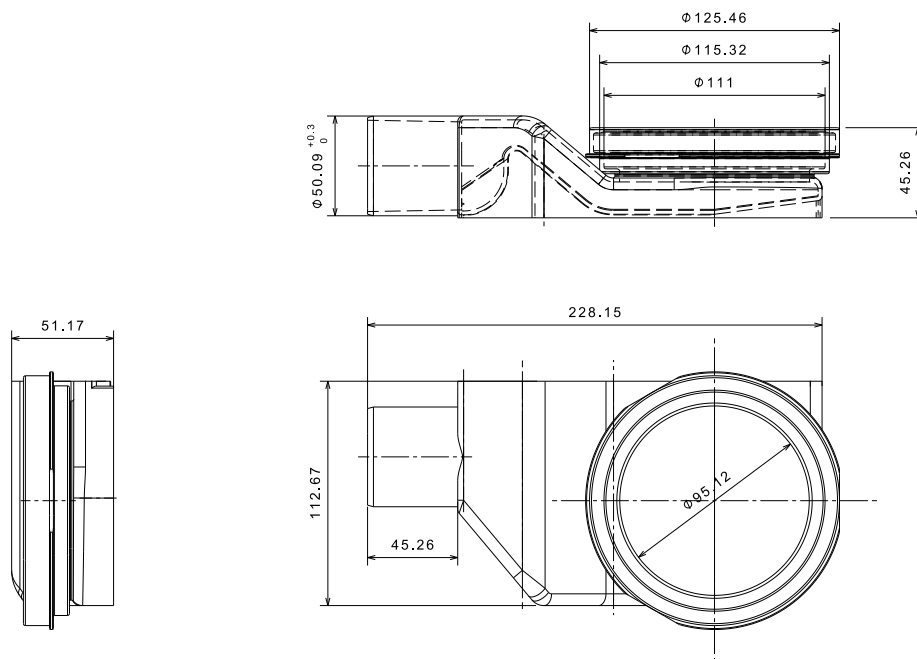

ultra S baza

